

AQUATICA™

Digital



INSTRUCTION MANUAL FOR

AQUATICA AD40x

Housing for the Nikon D40 & D40x

FOREWORD

Thank you for having selected the AQUATICA Digital Camera Housing System for your underwater photography.

The AQUATICA Digital Housing is the result of a long and continuing relationship with the most demanding underwater photographers in the world. Each housing is handcrafted, quality checked and **pressure tested to 300 feet** by a small group of specially trained individuals, each of whom takes the utmost pride and satisfaction in offering the best underwater camera housing in the world.

The Aquatica Digital Housing was designed for optimum technical and optical performance and to provide easy and efficient underwater access to essential functions and controls of the Nikon D40 & D40x DSLR.

This manual assumes that the User is already familiar with the Nikon D40 & D40x. If not, please read the Nikon instruction Manual before attempting to use the housing.

With basic care and maintenance, your AQUATICA housing will give you a lifetime of enjoyment and satisfaction in producing underwater images.

Please read this manual carefully before using your housing for the first time and note that: wherever cited the right hand is your right when using the housing.

SAFETY PRECAUTIONS

Improper transportation handling or use of this housing might cause a flood or malfunction.

Please read and follow the following precautions:

- Store and transport the housing in a sturdy, shock proof container and avoid travelling with the camera mounted inside the housing as impact forces especially on the external push buttons will be transferred to the camera.
- When travelling by air, either remove the port or open the housing.
- Never change a port or open the housing in a location where sand or similar foreign material might come in contact with an O-ring.
- Use of accessories or modifications and alterations unauthorized by the manufacturer may result in flooding or poor functioning of the controls
- Be careful when opening the housing as the pressure buildup inside the housing will exaggerate the force of the latch spring. Keep fingers away from the path of the latches.
- Whenever changing ports or O-rings, perform a simple seal test with out the camera inside.
- Avoid scratching the acrylic or glass ports and windows.
- Make sure that all ports remain properly attached before rinsing the housing, especially when rinsing without a strobe make sure the bulkhead connector is sealed with its plug.
- The main O-ring seals should be maintained and cleaned on a regular basis. Read and follow the Care and maintenance instructions on this manual.
- Ensure that the spring loaded secondary lock is properly engaged to prevent the accidental opening of latches.

AQUATICA™

Digital

AD40x

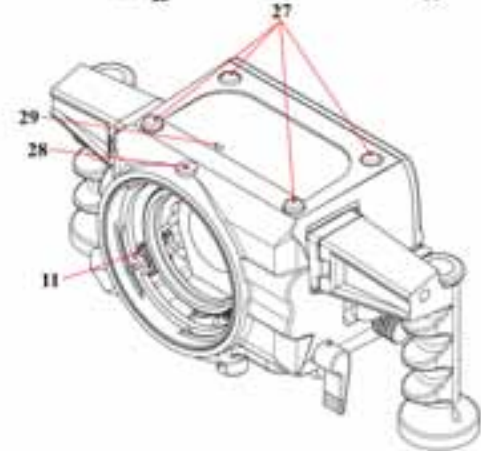
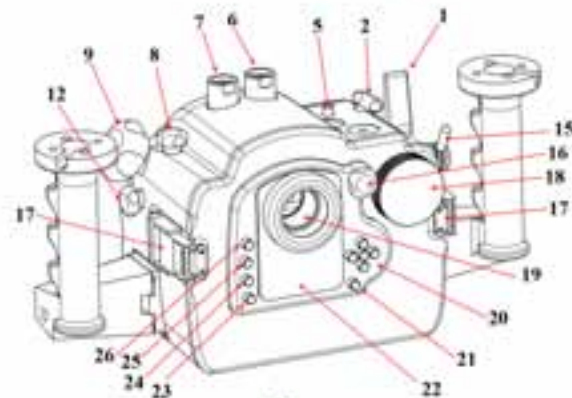
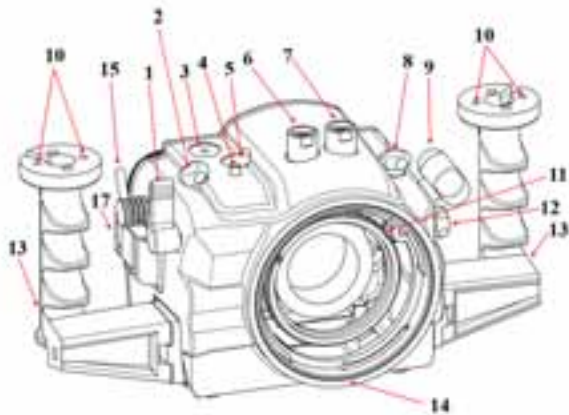

1. SHUTTER RELEASE LEVER
2. APERTURE & EXPOSURE COMPENSATION CONTROL KNOB
3. ACCESSORY MOUNTING HOLE (1/4" X 20)
4. SHOOTING INFORMATION BUTTON
5. MODE DIAL CONTROL WINDOW
6. MAIN BULKHEAD FOR FLASH CONNECTOR
7. OPTIONAL SECONDARY BULKHEAD FOR FLASH CONNECTOR
8. FLASH EXPOSURE COMPENSATION / MODE KNOB
9. FOCUS/ZOOM KNOB
10. HOLES (1/4" X 20) FOR ARM'S BASE BRACKETS
11. FOCUS/ZOOM MECHANISM PINION GEAR
12. LENS LOCK RELEASE LEVER
13. GRIPS (X2)
14. BAYONNET MOUNTING FLANGE
15. AE-L / AF-L LOCK LEVER
16. MODE DIAL SELECTION KNOB
17. LATCHES (2X)
18. COMMAND DIAL KNOB
19. VIEWFINDER
20. FOCUS AREA / MULTI SELECTOR / OK BUTTONS
21. DELETE BUTTON
22. REAR VIEW LCD WINDOW
23. PLAYBACK / ZOOM & i / RESET BUTTON
24. THUMBNAILED / HELP BUTTON
25. MENU BUTTON
26. PLAYBACK BUTTON
26. RUBBER ANTI SKID PADS (4X)
28. SACRIFICIAL ANODE
29. MOUNTING HOLE (1/4" X 20) FOR TRIPOD OR TRAY

CONTROLS IN DETAIL

- 1. SHUTTER RELEASE LEVER:** Pulling the shutter release lever back part way activates the camera meter and auto focus. Pulling the lever back all the way fires the camera.
- 2. APERTURE KNOB / EXPOSURE COMPENSATION KNOB:** Rotates knob to engage . Use in combination with the command knob controls to select the exposure compensation or aperture in manual mode.
- 3. MOUNTING HOLE FOR ACCESSORIES:** a 1/4"-20 TPI hole is provided to accept variousTLC accessories.
- 4. SHOOTING INFORMATION / RESET BUTTON:** when pressed, will display the shooting information on the rear display. for more on this button please refer to the camera instruction manual. this used in conjunction with the playback button (25) will reset your camera to its default values.
- 5. MODE DIAL WINDOW:** Allows viewing of the mode dial for selection.
- 6. BULKHEAD CONNECTOR:** A standard Nikonos type connectors i supplied for Flash Sync Cord.
- 7. OPTIONAL BULKHEAD CONNECTOR:** A second standard Nikonos type connector can be supplied for additional Flash Sync Cords or for using the accessory underwater remote cord.
- 9. FLASH SYNC MODE / EXPOSURECONTROL BUTTON:** Turn to activate the flash mode selector function, rotate command knob to desired flash sync mode. Exposure compensation is not accessible on non TTL strobes.
- 10. MOUNTING HOLE:** These are 1/4-20 TPI holes that are ready to accept TLC Base Brackets or TLC Base Ball for strobe arms or accessories.
- 11. FOCUS/ZOOM KNOB:** Turning allows manual focus of a single focus lens or rotation of the zoom mechanism of a lens.
- 12. LENS RELEASE LEVER:** activates the lens release button on the camera allowing easy removal of the lens.
- 13. HAND GRIPS (X2) :** Left and right grip allowing the mounting of strobe arms and accessories.
- 14. BAYONNET MOUNTING FLANGE:** allows the mounting of different ports and extension rings on the housing.
- 15. AF / AE LOCK LEVER:** Press down lever to engage auto focus or/and auto exposure, see camera manual for the different options associated to this button. also used for delete protection in playback mode.
- 16. MODE DIAL SELECTION KNOB:** Rotates clockwise and counterclockwise to select the proper shooting mode. Using mode other than A, S, M or P may. Refer to camera manual for in depth use.
- 17. LATCHES:** Two heavy duty latches are provided with safety locks to protect against accidental opening.
- 18. COMMAND INPUT KNOB:** It rotates clockwise and counterclockwise. It can be used alone or in combination with other controls to select or set various camera functions or modes. Refer to camera manual for in depth use.
- 19. VIEWFINDER:** A full view of the illuminated camera viewfinder displays all necessary information.
- 20. FOCUS AREA / MULTI SELECTOR BUTTONS:** These buttons have multiple uses. They allow the selection of the focus area, in the menu mode, they are used to scroll up or down and left to right to choose from your menu selection and they are used in the delete mode. pressing the center one will confirm your selection.

Controls in detail, continued

21. DELETE BUTTON: Press to delete images, use multiple selector buttons to select and press the enter button to delete.

22. REAR VIEW DISPLAY WINDOW : allow viewing of menu and images

23. PLAYBACK ZOOM / INFO / RESET BUTTON: use for zooming in playback mode, to display info on the rear LCD and to reset camera to its defaults setting when used in conjunction with the top shooting information button (#4)

24. THUMBNAIL / HELP BUTTON: Press to display images in “contact sheets” of 4 or 9 images, also displays the information if a problem is encountered

25. MENU BUTTON: Press to activate menu, use multi selectors buttons (21) to navigate, press enter button (25) to choose a selection.

26. PLAYBACK BUTTON: Press to activate the monitor and review images.

27. RUBBER PADS: Those four pads are supplied to prevent your housing from skidding on wet surface

28. SACRIFICIAL ANODE: A zinc anodes is installed underneath to protect your housing against salt water corrosion; this anode is made to deteriorate easier than the other strategic part of your housing, hence the name sacrificial anodes. This anodes will need to be replaced overtime and as needed.

29. MOUNTING HOLE: a 1/4" X 20 holes are provided for mounting strobes trays or accessories.

24. REAR VIEW DISPLAY WINDOW : allow viewing of menu and images

25. ENTER / PLAYBACK ZOOM BUTTON : Press to acknowledge selected function or use for zooming in playback mode.

26. PROTECT BUTTON: Press to protect selected image from accidental deletion.

28. MENU BUTTON: Press to activate menu, use multi selectors buttons (21) to navigate, press enter button (25) to choose a selection.

29. PLAYBACK BUTTON: Press to activate the monitor and review images.

31. BRACKETING BUTTON: Push to activate the bracketing function, rotate main command knob to desired exposure correction.

32. FOCUS MODE SELECTOR LEVER: Rotate to select between manual, single or continuous focusing. SELECTOR LEVER FORK: Must be in M (manual) position when sliding camera in the housing, once installed, desired focus mode can be selected.

FEATURES

The Aquatica Digital housing series is issued from the world's most technologically advanced underwater housing lineage, ergonomically designed to place all the essential camera controls under your finger tips and features the following:

A. A Lens Lock Release control that will activate the lens release button of camera from the outside of the housing.

B. A quick release tray, allowing fast and easy removal of camera.

C. Large ergonomic and easy to operate controls for most of the manual and computerized camera functions.

D. The following controls can be easily manipulated underwater:

- Mechanical shutter release.
- Shutter speed through Main-Command Dial
- Aperture through the Command Dial
- Focus or Zoom
- Shooting mode information through top and rear windows
- Metering system selector
- Auto Bracketing (BKT)
- Exposure mode (Mode)
- Exposure Compensation
- Focus Area Selector
- ISO sensitivity
- White balance
- Delete button access
- Flash sync mode

E. A complete selection of bayonet mounted ports including a compact 6" acrylic, an 8 inches acrylic and a larger BK-7 glass 9,25 inches diameter dome, two flat ports and a selection of extension rings to preserve the image quality for most of the underwater usable Nikkor AF and other popular brand of AF lenses.

F. A complete line of lens gears and related accessories. (refer to lens chart on page 14 for more detail)

PREPARATION OF THE HOUSING

1. Attach Grip Bracket to the housing:

The housing comes with two Grips for both right and left hand grips which should be installed on the sides of the housing with the supplied screws and Allen key. Occasionally remove the grips and lubricate the screws (see Care and Maintenance: of the housing.)

Depending on which strobe system you are using, you can mount the necessary shoes or brackets onto the 1/4"-20 threaded holes on the top of the hand grips. The AQUATICA TLC strobe arm system is recommended.

There is also a 1/4"-20 threaded hole on the bottom of the housing that can be used for various mounting application such as trays or tripods. As well there is a similar hole on top of the housing for mounting accessories such as a focusing light.

Mount your strobe and connect the sync cord to the housing's strobe bulkhead. Be sure to read the section titled "Care and Maintenance: of the O-rings."

2. Lubricate the Main O-ring Seal:

Before use, remove the Main O-ring seal from its groove on the rear part of the housing and carefully verify that the O-ring and the O-ring groove are free from scratches or foreign material. Lubricate the O-ring with a light coat of silicone grease.

When replacing the O-ring place the entire O-ring over the O-ring groove and start by pushing the O-ring in the corners. Work your way around the O-ring making sure the O-ring is snugly sitting in the groove.

For proper handling and maintenance of O-rings be sure to read the section titled "Care and Maintenance: of the O-rings."

PREPARATION OF THE PORTS

1. Select the correct port:

Depending on whether you've decided to shoot macro or wide angle photography, you will be installing either a flat Macro Port or a Dome Port.

Refer to the lens selection chart on page 14 for the recommended port .

Or visit our web site www.aquatica.ca for the latest updated chart of lenses, port and accessories.

EXTENSION RINGS

Macro Port Extension Rings: the Macro Port will accept the AF Micro-Nikkor 60mm lens. If you intend to use a longer lens such as the 105mm or 200mm Micro Nikkor you will require an extension rings that fit between the Macro Port and the housing to provide the extra space necessary for the longer lens.

Dome Port Extension Rings : an extension ring might be needed between the dome and the housing to optimise the optical performance when using a wide angle or zoom lens.

In order to reduce glare, maximize contrast and offer physical protection to the dome, the use of a dome shade for the 6" & 8" domes is recommended (the 9.25" glass dome has an integrated shade).

Refer to the lens selection chart on page 14 for the proper extension ring if needed.

Or visit our web site www.aquatica.ca for the latest updated chart of lenses, port and accessories.

2. Clean the port:

Dirt, grease or fingerprints on the port especially on the inside, can adversely affect the quality of the image. Acrylic ports should be cleaned with plastic cleaner and the glass ports should be cleaned with lens cleaner. For more details be sure to read the section titled "Care and Maintenance: of the Ports."

3. Lubricate the port O-ring seal:

Before using the port, remove the O-ring on the rear of the port and lightly coat it with silicone grease. For more details be sure to read the section titled "Care and Maintenance: of the O-rings."

PREPARATION OF THE LENS

Depending on the lens used, there are a number of gear options possible. Using the right gear and correctly mounting it on the lens is very important for a smooth housing operation. Use the provided chart to determine which gear to use and follow the installation directions for each gear carefully. Since the aperture control is achieved through the Command Dial, the use of AF types of lenses is mandatory. The focus/zoom gear can vary from one lens to the other.

Refer to the lens selection chart on page 14 for compatible lens,

For manual focus operation a focus gear must be mounted on the lens. If you are using a zoom lens with a zoom ring the camera must be on auto focus, also note that if using a dome port you may need to install a closeup diopter on the lens to correct the minimum focusing distance of the lens so that it will be able to focus on the virtual image created by the dome.

Focus Gear installation:

1. Mount the focus gear over the focus ring of the lens such.

2 (a) For Slip-on gears (gears without mounting screws): Slide the gear over the lens and align the gear with the front of the lens focusing ring. Internal rubber o-rings can be cut for adjustment if the gear is too tight.

(b) For gears with mounting screws: Tighten the set screws evenly. Tighten each screw approximately $\frac{1}{2}$ a turn working around the gear until all the screws are tightened and the gear is concentric with the lens body.

CAUTION: Do not over-tighten these screws, as this might bind the lens barrel, thus restricting the rotation of the focus ring and/or damaging the lens. Conversely under-tightening these screws might cause the gear to slip or loose alignment.

4. Rotate the focus ring several times to make sure it moves smoothly and the gear does not slip before closing the housing

Zoom lenses: When using a zoom lens, the gear should be mounted on the lens zoom control ring.

The knob (key #6) on the housing then becomes the zoom control. Focusing of lens is achieved by using the camera's autofocus system.

CAMERA PREPARATION AND INSTALLATION

1. Set the exposure Mode Selector to one of the four following position on the camera. Manual, aperture priority, shutter priority or programmed auto. modes that allows the built in flash of the camera to pop up are unusable when the camera is in the housing, manual and aperture priority are the most used shooting mode underwater and mastering these should be a priority for the underwater photographer.

2. Important Note: Accessories “D” Clips that attach straps should be removed or tucked away prior to installing the camera in the housing.

3. Remove the saddle from the housing and carefully place the camera on it and ensure the camera is properly installed and aligned as follows:

a) The camera is properly aligned and secured against rotation or movement.

b) Align the Tripod Socket of the camera with the mounting screw. Tighten the mounting screw securely while ensuring that the camera position is not altered.

d) Slide the quick release tray back into place.

e) The saddle has a ball bearing tensioner to prevent the housing from slipping too easily, nonetheless the camera and the tray are only locked into place when the rear cover of the housing is installed and care should be take not to flip the housing when the back is not attached.

4. Once the camera is secure on the saddle inside the front half of the housing, simply slide the housing’s hot shoe connector onto the hot shoe base of the camera as seen in drawing at right.

5. Make sure the camera switch is in the ON position before closing the housing.

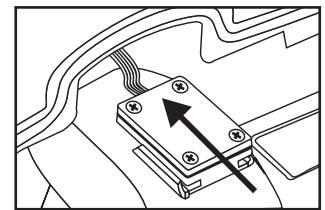
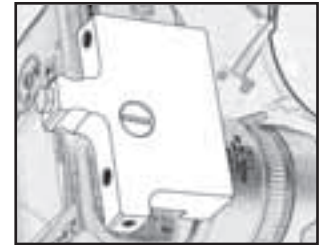

CLOSING OF THE HOUSING

Before closing the housing always ensure that:

1. The main O-ring on the rear part of the housing is clean, lubricated and properly seated for a positive seal.

2. The sealing surface on the front part of the housing is clean and free from any scratches or physical damage.

3. All cords or wires are tucked in so that they do not interfere with the closing of the housing.

To close the housing simply:

i. Join the front and rear halves of the housing using the dowel pins of the housing as a guide.

ii. Hold the housing with both hands and look around the sealing surface to ensure that the O-ring remained properly seated and that no cords, wires or “D-rings” are caught between the edges.

iii. Close the two sides latches simultaneously, confirm that the locking mechanism of the latch is engaged. For opening the latches, push the locking mechanism tab and reverse the process.

CAUTION: if you feel any resistance as you attempt to close the latches, do not force the closure. Check for obstructions and try again.

LENS INSTALLATION

With the camera inside the housing, install the lens prepared with the gears through the port opening in the front of the housing. Ensure that the lens mounted gears are properly installed and aligned. Rotate the focus / zoom control knob to ensure that the gears are properly meshed, do not grind and that their rotation is smooth.

Note: The D40x camera is designed to use AFS type lens if regular AF lenses are to be used a manual focus gear will be required.

CHANGING A LENS (REMOVING A LENS)

The lens mounted gears may restrict the view and ease of access to the lens release button of camera. The AQUATICA Pro Digital Housing features a Lens Release Lever (key # 12) that is designed to trigger the lens release button of camera to allow easy removal of lens.

To remove a lens, simply:

Rotate Lens Release Lever (key # 12) counterclockwise, hold and turn the lens clockwise.

MOUNTING THE PORT

Before mounting the Port on the Housing always ensure that;

- The port O-ring is clean, lubricated and properly seated in its groove.
- The sealing surface on the Housing is clean and free of physical damage.

The AQUATICA Digital Housing System features a bayonet mount. To mount the port or extension ring simply:

1. Place the housing on its back on a soft steady surface.
2. Place the port or extension ring inside the main port of the housing. Align one of the four alignment notches with the opening of the housing.
3. Place your hands on opposite sides of the port or extension ring.
4. Push with even force on both sides of the port or extension ring until you feel it snap into place. Make sure the bayonet is completely inside the housing.
5. Finally turn the Port clockwise until it stops. Do not force it. If there is too much resistance take the port off, check the O-ring and retry.
6. Check to ensure for the proper seating and sealing of the port on the housing.

Note : It is recommended that you familiarize yourself with this mount by trying it without the camera, this will allow you to see the inside view of the bayonet mount and of the ports or extension rings in the housing.

MOUNTING AND ATTACHING FLASHES

Depending on which strobe system you are using, you can mount the necessary shoes or brackets or Base Ball onto the threaded holes on the top of the hand grips. Use of the Aquatica TLC Strobe Arm System is recommended. There are also a 1/4"-20 threaded hole on the bottom of the housing that can be used for various mounting applications. For example, another 1/4"-20 threaded hole on top of the front half of the housing will accept an Aquatica Base Ball that can hold a small dive light or a strobe arm.

The AQUATICA Digital housing is comes with a standard single strobe connector, to this a second bulkhead connector for strobes can be added or the original one can be replaced with a Ikelite type bulkhead connector.

- When inserting the sync cord(s) be sure to lubricate the O-ring on the sync cord's connector with a light coat of O-ring grease. Also put a light coat of O-ring grease on the threads of this connector.

TAKING A PICTURE

Following are the basic techniques. For more information and advanced photography please study the original camera instruction manual.

1. Selelection of the exposure Mode (key # 16) is achieved by rotating the knob to the desired exposure mode, usable exposure mode options are: Programmed Auto (P), Shutter Priority Auto (S), Aperture Priority Auto (A) or Manual Exposure (M).

2. Control of Auto Exposure compensation (key# 2) is achieved by rotating the knob and positioning over the button to engage compensation function, select proper factor by rotating command knob (key# 18) .

Note: When using a flash, it is reccomended that the camera be used only in Single Frame Motor Drive or there is the possibillity that the camera will fire before the flash can recycle.

3. Pull the Shutter Release Lever partially back. This will activate the camera's meter and autofocus system.

4. If using manual focus use the Focus Knob (key # 9) on the housing or on the flat port to focus.

5. If using the Manual, Aperture or Shutter priority mode adjust the Command Knob (key # 18) and/or aperture/compensation knob (key # 2) to set the shutter speed and/or aperture.

6. Pull the Shutter Release Lever (key # 1) the rest of the way until the camera fires.

FOCUSING MODE

NOTE : Select the proper focus mode using the cameras menu. For more detailed information concerning the operation of the different focus modes consult the camera's original instruction book.

USING THE HOUSING

Whenever changing ports or O-rings, it is highly advisable to perform a simple seal test without the camera inside. Strapping a weight to the housing and lowering the unit to a depth of 30 to 50 feet of water for at least 10 minutes will assure you that the seating of the new port or o-ring is proper. This test, though time consuming and often considered unnecessary, may save your camera equipment from irreparable water damage. The housing is now ready for the dive.

CAUTION: Never jump into the water with the housing. It is best to have the system handed to you after you have made your entry, or have it lowered to you on a rope. Make certain that ropes, lines of other equipment stay clear of the system. When photographing, be sure to respect the environment. Avoid damaging marine life or manipulating sea creatures to obtain a pleasing photo. The housing is slightly negatively buoyant so that you can lay it down on the bottom, but avoid laying it on living coral or other delicate marine life. Before immersing the housing always confirm visually that your port is properly installed, this should be done also before rinsing at the end of the dive or whenever the housing has been handled by others.

Changing the memory card

Always take care to thoroughly dry the housing before opening it to change memory card. Wipe the housing off with a dry towel. If possible it is suggested that the housing be blown dried by directing an air nozzle around the main o-ring before opening. Rest the housing on its front with the lens facing down, be carefull to protect the port surface, release the two side latches simultaneously. Lift the rear part of the housing and place it in a secure location. This minimizes the possibility of any residual water falling into the housing and on to the camera when the housing is opened or damage to the sealing surface. gently pul the housing back to access the card compartment.

TRANSPORTING THE AQUATICA Digital housing

Store the AQUATICA Digital housing in a sturdy, shock proof container. When travelling by air, remove the port. This allows for equalization of the air pressure inside the housing to the external air pressure. Failure to do so may cause serious damage to your ports. Avoid travelling with the camera mounted in the housing. If you must do so, remove the lens as external pressure can damage the camera.

CARE AND MAINTENANCE

Of the housing:

After each and every salt water dive, your housing system should be soaked or rinsed in fresh water. The housing system should soak in fresh water for at least 30 minutes. During this soaking period reach into the water and operate all the controls several times. Always confirm that your port and strobes are securely attached before soaking the unit in the rinse tank. Whenever entering the water with a housing especially after having travelled by boat to the destination, you need to check for alignment and confirm that the port or extension ring has not rotated during transit or handling by you or any other person.

Ports cap and housing body caps are for wear and tear protection only **they are not** watertight and should ***never be used underwater***

Be sure to remove the housing's main o-ring and clean it after every use. Refer to Maintenance: Of the O-rings. To ensure that the hand grips won't fuse on to the housing due to the exposure to salt water, it is also a good practice to occasionally remove the hand grips. Clean and lubricate the bolts with a small amount of WD-40.

WARNING: Use WD-40 carefully, sparingly and only on metal to metal surfaces. WD-40 can damage the acrylic on the ports, the optical surfaces on lens as well as the O-rings.

Of the Ports:

Care should be taken with the Dome Port and Macro Port to avoid scratches on the lens surface. The acrylic port is softer than glass so minor exterior scratches are often unavoidable. However, since the indices of refraction for acrylic and water are almost equal the scratches will not seriously impair image quality. Internal scratches(air side) must be avoided as they do not fill in with water and will affect the quality of the image.

Clean the acrylic surface of the dome using only products recommended for cleaning acrylic and a soft lint free cloth. Dust on the interior surfaces of the port can be removed with a soft camel hair brush or a blower brush. Caution must be taken when using aerosol devices as not to spray the lens material with the liquid propellant as this may seriously affect the optical properties of the port. The ports should be removed and serviced after every dive.

Of the Latches:

The two latches of the AQUATICA Digital housing are designed to have a locking action to prevent accidental opening. Always ensure that the locking mechanism is secure. Watch for the build-up of corrosion or salt residue around the latches. This will appear as a white material. Lubricate the latches with a small amount of WD-40 to remove the corrosion or salt residue build-up.

Of the O-Rings:

The O-rings that need to be maintained on a regular basis are the main housing O-ring and the O-ring on the lens port.

The main O-ring should be cleaned on a daily basis and the port O-ring should be cleaned daily or each time the port is changed.

Of the sacrificial anodes:

The anode attached to the bottom part of the housing is there to prevent corrosion due to electrolysis, as time goes they will deteriorates and will need replacement, contact Aquatica for replacement and procedure of their installation.

TO SERVICE O-RINGS ON THE HOUSING MAIN O-RING, PORTS AND EXTENSION RINGS

1. Remove the O-ring. It is important never to use a sharp instrument when removing an O-ring as this may damage the O-ring groove or the O-ring itself. A bobby pin or edge of a credit card works well.
2. Once the O-ring is removed, it should be examined for damage. Check to make sure that the O-ring is free of nicks and cuts and that it retains its original round profile. O-rings that appear to be damaged should be discarded immediately and replaced with new O-rings.
3. Rinse the O-ring with fresh water and dry it with a clean lint free cloth.
4. Clean the O-ring groove (where the O-ring sits) with a Q-tip. Be sure to remove any lint the Q-tip may leave behind. Inspect the groove for damage.
5. Wipe the part of the housing that the O-ring seals against with a clean lint-free cloth.
6. Re-grease the O-ring with a thin layer of O-ring grease until it appears to be smooth and shiny. Do not over grease it. Use just enough grease so the O-ring will pull smoothly through your fingers. Excessive amounts of grease will only serve to attract dirt to the o-ring.
7. Make sure that the O-ring is properly (evenly) installed in the O-ring groove.
8. To reinstall the clean and lubricated O-ring, place the entire O-ring over the groove and start by pushing the O-ring in at each corner then, push the O-ring at each side and finally, work in the rest of the O-ring. Never start at one end and work your way around the O-ring. This places uneven tension on the O-ring which may cause the O-ring to stretch resulting in excess O-ring, which will have no place to go.

There are internal O-rings on the housing controls as well. These O-rings are not as susceptible to damage as they are not exposed but they do require yearly maintenance and are not user service-able. The housing should be returned to AQUATICA or to an authorized AQUATICA service facility for this annual maintenance. Check the Web site www.aquatica.ca for the closest service center.

An internal moisture alarm is available for your AQUATICA Pro Digital housing (Product # 20023). This alarm is available through your authorized AQUATICA dealer and can be easily installed.

RECOMMENDED AQUATICA ACCESSORIES

AQUATICA
Digital

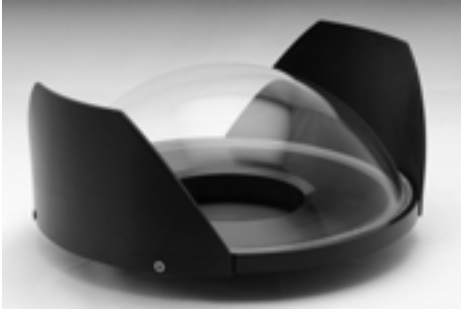

18407 9.25" GLASS DOME



18405 8" ACRYLIC DOME



18426 FLAT MACRO PORT



20054 AQUA VIEW FINDER



18789 HOUSING BODY CAP

EXTENSION RINGS



19216 HARD TRANSPORT CASE FOR AQUA VIEW FINDER



18480 DOME SHADE F.E.



18790 PORT REAR CAP



20023 MOISTURE ALARM



18480 DOME SHADE W.A..



ZOOM & FOCUS GEARS

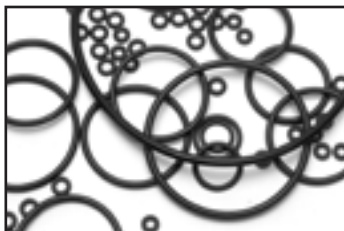

MAINTENANCE & REBUILT O-RING KITS

Technical Lighting Control™



Please visit our website at www.aquatica.ca for a complete selection of our Technical Lighting Control line of strobe arms and supports.

WARRANTY

PLEASE READ CAREFULLY

One year Limited Warranty.

Thank you for purchasing an AQUATICA manufactured product! Your AQUATICA housing is handcrafted by a small group of specially trained individuals - each of whom takes the most pride and satisfaction in offering you the best underwater camera housings in the world. All AQUATICA products are guaranteed against defects in material or workmanship for (1) one full year from the date of purchase for consumer use. these same products when used commercially will carry a 90-day warranty. No statutory warranty applies. Camera housed in AQUATICA housings are not covered under this warranty and ANY WATER DAMAGE SUSTAINED DUE TO INSTALLATION ERROR OR ANY OTHER REASON IS NOT THE RESPONSABILITY OF AQUATICA. Therefore the appropriate insurance should be maintained by the user.

Warranty does not apply to replaceable seals or damages to impacts or abrasive surfaces. Warranty applies only to products purchased from authorized AQUATICA dealers and does not extend beyond the original retail purchaser. Unauthorized modifications or repairs will automatically void this warranty. this applies to removal of serial numbers and AQUATICA identification labels.

To obtain service during or after the warranty period you must notify AQUATICA at 514-737-9481 and ship BY REGISTERED MAIL (INSURED) **ONLY**, enclosing your proof of purchase to:

AQUATICA
3025 De Baene
Montreal (Quebec)
H4S 1K8

Mark clearly on your package "Canadian goods returned for repair"

Do not ship by any other means.
Unauthorized packages will be refused.

YOUR SERIAL NUMBER _____

The logo for AQUATICA Digital. The word "AQUATICA" is written in a blue, serif font with a small trademark symbol. Below it, the word "Digital" is written in a red, sans-serif font. A blue horizontal line is positioned between the two words.